

# Active Damping of Ultrafast Mechanical Switches for Hybrid AC and DC Circuit Breakers

Chang Peng<sup>1</sup>, Member, IEEE, Landon Mackey<sup>2</sup>, Member, IEEE, Iqbal Husain<sup>3</sup>, Fellow, IEEE, Alex Q. Huang, Fellow, IEEE, Wensong Yu, Member, IEEE, Bruno Lequesne, Fellow, IEEE, and Roger Briggs

**Abstract**—An active damping method for Thomson coil actuated ultrafast mechanical switches is proposed, including its control. Ultrafast mechanical switches are crucial for both dc and ac circuit breakers that require fast-acting current-limiting capabilities. However, fast motion means high velocity at the end of travel resulting in over-travel, bounce, fatigue, and other undesirable effects. The active damping proposed in this paper not only avoids such issues but actually enables faster travel by removing limitations that would otherwise be necessary. This active damping mechanism is applicable in particular to medium- and high-voltage circuit breakers, but can be extended to actuators in general. A 15 kV/630 A/1 ms mechanical switch designed to enable the fast protection of medium voltage dc circuits is used as a testbed for the concept. The switch is based on the principle of repulsion forces (Thomson coil actuator). By energizing a second coil, higher opening speeds can be damped, resulting in limited over-travel range of the movable contact. The overall structure is simple and the size of the overall switch is minimized. To validate the concept and to study the timing control for best active damping performance, both finite element modeling and experimental studies have been carried out.

**Index Terms**—Active damping, dc circuit breaker (DCCB), finite element method (FEM), hybrid circuit breaker, repulsion coil actuator, Thomson coil actuator, ultrafast mechanical switch (UFMS).

## NOMENCLATURE

|      |                              |
|------|------------------------------|
| DCCB | DC circuit breaker.          |
| UFMS | Ultrafast mechanical switch. |
| CS   | Commutating switch.          |

Manuscript received December 16, 2016; revised February 26, 2017 and June 30, 2017; accepted July 12, 2017. Date of publication August 16, 2017; date of current version November 20, 2017. Paper 2016-EMC-1256. R2, presented at the 2016 Energy Conversion Congress and Exposition, Milwaukee, WI, USA, Sep. 18–22, and approved for publication in the IEEE TRANSACTIONS ON INDUSTRY APPLICATIONS by the Electric Machines Committee of the IEEE Industry Applications Society. This work was supported by the University of North Carolina Coastal Studies Institute. (Corresponding author: Chang Peng.)

C. Peng is with Hyperloop One, Los Angeles, CA 90021 USA (e-mail: pc.pengchang@gmail.com).

L. Mackey, I. Husain, and W. Yu are with the FREEDM Systems Center, Department of Electrical and Computer Engineering, North Carolina State University, Raleigh, NC 27695 USA (e-mail: lkmackey@ncsu.edu; ihusain2@ncsu.edu; wyu2@ncsu.edu).

A. Q. Huang is with the University of Texas at Austin, Austin, TX 78712 USA (e-mail: aqhuang@ncsu.edu).

B. Lequesne is with E-Motors Consulting, LLC, Menomonee Falls, WI 53051-8330 USA (e-mail: Bruno.lequesne@ieee.org).

R. Briggs is with Energy Efficiency Research, LLC, Colgate, WI 53017 USA (e-mail: roger.briggs@eer-llc.com).

Color versions of one or more of the figures in this paper are available online at <http://ieeexplore.ieee.org>.

Digital Object Identifier 10.1109/TIA.2017.2740830

|      |  |
|------|--|
| MB   | Main breaker.                                      |
| MOV  | Metal-oxide varistor.                              |
| IGBT | Insulated-gate bipolar transistor.                 |
| TRV  | Transient recovery voltage.                        |
| FEM  | Finite element method.                             |
| IEEE | Institute of Electrical and Electronics Engineers. |

## I. THOMSON COIL ACTUATED UFMS FOR HYBRID DCCB

MEDIUM- and high-voltage hybrid DCCBs combine electronic switches with mechanical switches in parallel [1]–[6]. They consist of four primary components for current conducting, commutation, and interruption as shown in Fig. 1; an UFMS or disconnecter, a low-voltage solid-state switch as the CS, a high-voltage solid-state switch as the MB and MOVs. The high-voltage solid-state switch is composed of antiseriess IGBTs, denoted as two IGBT symbols with diodes in the diagram. They in fact represent strings of devices to meet the requirement of the nominal voltage rating. The hybrid solid-state DCCB scheme that exploits a low-voltage CS in series with an ultrafast mechanical disconnecter provides an ultrafast and highly efficient protection solution to power systems [2], [4]. In normal conduction, the current flows through the nominal path that consists of UFMS and CS. In order to interrupt a fault current, first the CS turns off in a few microseconds and commutates current into the MB in a few tens of microseconds. The UFMS opens and forms a gap between its contacts that can withstand the high voltage that will result from the subsequent turn-off of MB.

Though the hybrid circuit breaker concept was originally proposed to interrupt a dc circuit, it fits ac applications as well. As a matter of fact, since the interruption operation is finished as fast as in a couple of milliseconds, it is faster than usual ac periods (at 50 or 60 Hz), such that an ac circuit acts like a dc circuit as far as the hybrid circuit breaker is concerned. Because of the subquarter cycle operation, the hybrid circuit breaker can, therefore, also limit the fault current in ac circuits.

The effectiveness of these hybrid ac and dc circuit breakers is predicated on the mechanical switch opening as fast as possible to obtain a sufficient gap between the open contacts, so that they can withstand the TRV following current interruption. This is because the total interruption time of the hybrid circuit breaker is dominated by the operation speed of the UFMS in such hybrid circuit breakers [1], [2], [7]–[10].

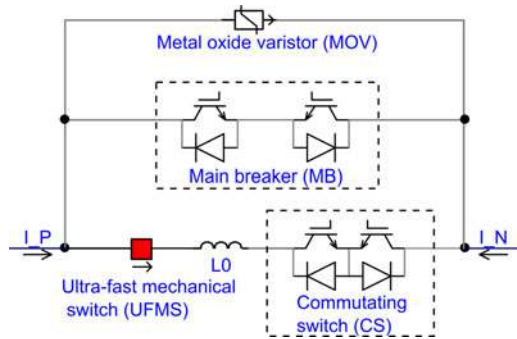

Fig. 1. Hybrid DCCB.

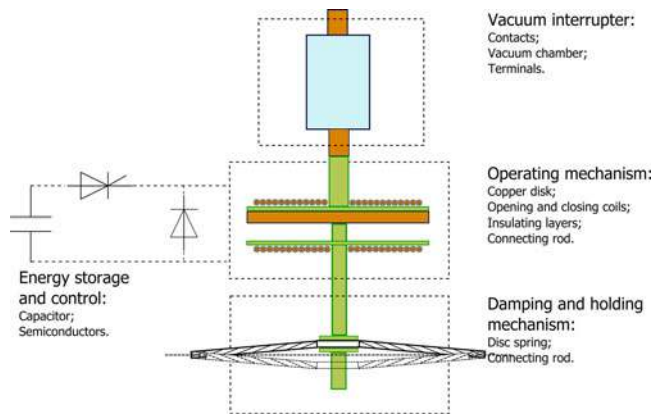

Fig. 2. Diagram of the Thomson coil actuator based fast mechanical switch.

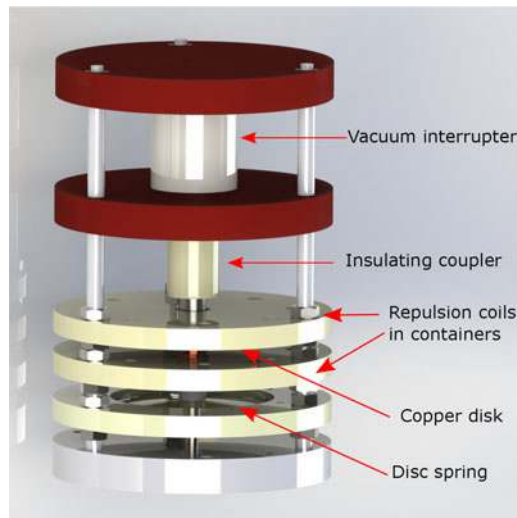

Fig. 3. Design of the UFMS.

The switches used in this type of circuit breakers are typically based on electromagnetic repulsion forces with current induced in a conductive copper disc (so-called Thomson coil actuator) [7], [8], [10]. The switch actually comprises two coils, one for the opening operation and one for the closing operation, located on either side of the copper disc (above and underneath, Figs. 2 and 3). To open the UFMS, the opening coil is energized so that a strong magnetic field is generated, which penetrates into the conductive disc. This time varying magnetic field induces

azimuthal eddy currents in the disc which in turn create an opposing magnetic field. These two fields oppose each other and a repulsive force is generated between the coil and the disc. Closing is obtained in a similar manner with the lower coil.

In this paper, an active damping mechanism and its control are proposed for this type of actuator, aiming to extend the practical limit of the operating speed by damping excessive energy out of the moving mass, and this is achieved by energizing the closing coil at the end of opening operation to stabilize the movement against possible over-travel and bouncing at high-speed operations. In doing so it becomes possible to actually excite the opening coil to higher levels, resulting in overall faster operation than would be possible without the active damping. This result will contribute to achieving ultra-fast operation for the switches and, therefore, the hybrid DCCB. With this control, superior performance is achieved. Further, the structure remains simple without adding extra damping mechanisms. Smaller vacuum interrupters can be used and the size of the overall switch remains compact. Work on a similar concept was recently published [11] indicating that others working on the issue of dc current breaking are facing the same difficulties. Similarly, in [10], the velocity of the moving part is seen increasing up to the end of motion, reaching a high 5–6 m/s, with no damping mechanism included in the design to absorb the corresponding kinetic energy upon end-of-motion impact. This paper adds to the literature a comprehensive parametric analysis as well as experimental investigations. The experimental study provides valuable quantitative results on different combinations of driving conditions of the opening and damping operations.

The paper includes finite element modeling of the active damping transients and test results obtained on a 15 kV/630 A/1 ms mechanical switch. The actuator design used in this paper is described in details in [8], and the drive circuits have been discussed in [9].

## II. RECLOSING ISSUE WITH PASSIVE DAMPING MECHANISM

The general issue addressed in this paper is the design of effective, reliable damping mechanisms to absorb the kinetic energy due to fast opening. Mechanical means are effective, but need to be tuned to the energy imparted to the system during opening. Not enough damping can lead to damage, and too much generates bounce and long effective travel time. If the bounce is large enough, the system recloses (opening failure). Therefore, a fixed damping can actually limit the opening energy and lengthen the travel time, by forcing the designer to use a level of energy below that which will lead to bounce. This was observed during initial tests of a prototype switch (shown in Fig. 4). In order to illustrate this, Fig. 5 shows a successful opening with a capacitor bank that is precharged to 400 V. The displacement curve is linear, overshoots, and finally settles at a steady-state open position. When driven by 420 V, however, see Fig. 6, the travel is initially faster but at the end of the travel and following the overshoot the switch does not stay at a steady-state open position. Instead it bounces back toward the closed position and the opening operation fails. The specific mechanism used in the experiments used nonlinear disc springs

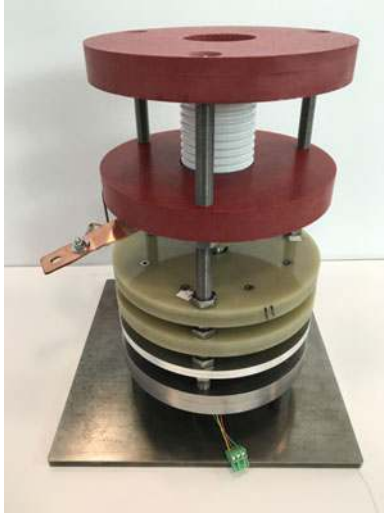

Fig. 4. UFMS prototype. (Base plate is approximately 30 cm  $\times$  30 cm.)

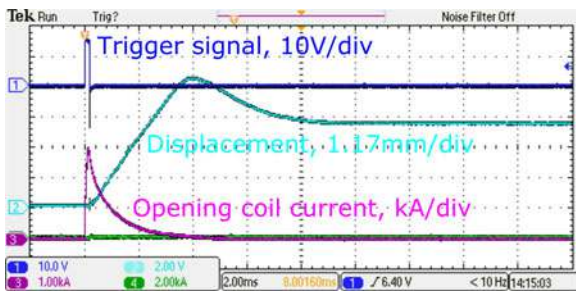

Fig. 5. Successful opening driven by 400 V.

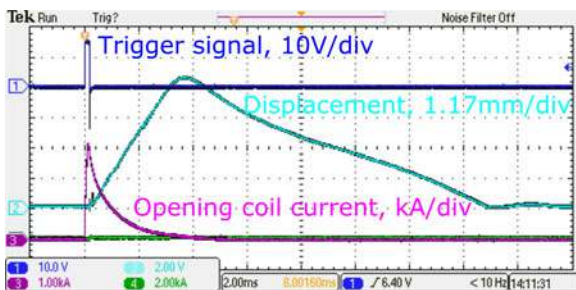

Fig. 6. Opening driven by 420 V followed by a reclosing.

(see [4] for a more detailed description of the design). Other mechanisms are possible [13]–[16] but all are expected to suffer from the same limitation due to their being set at the design stage, with no feedback control possible. With damping disc springs a few factors can affect the damping process, which are as follows.

- 1) The kinetic energy of the moving mass. Most of the energy is to be absorbed by the disc springs.
- 2) The nonlinear load-versus-deflection characteristic of the disc spring (see [8]) and how much energy the disc spring can absorb. The disc spring provides holding forces both at the open and closed positions, which correspond to

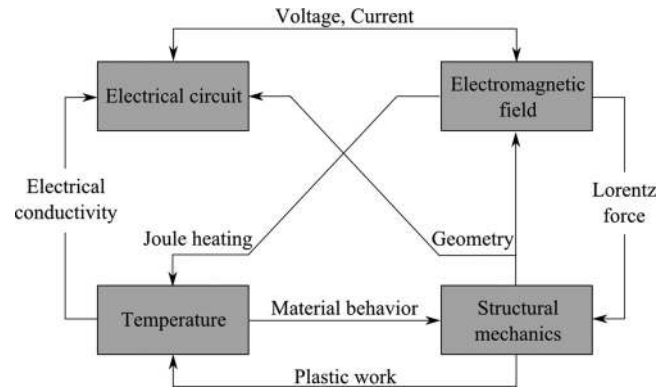

Fig. 7. Multiphysics interaction in the actuator.

different operation points on the load-versus-deflection curve.

- 3) The allowable over-travel during opening. Two components limit this over-travel range: The vacuum interrupter and the disc spring. A longer over-travel results in larger sizes for both components and, therefore, the overall size of the switch assembly.

### III. PROPOSED ACTIVE DAMPING FOR THOMSON COIL ACTUATED SWITCHES

This paper proposes an active damping method that utilizes the Thomson coils of such an actuator and does not require extra mechanical complexities in structure and design.

When the mechanical switch is to open, a large amount of energy is dumped into the opening coil, part of which is transferred to the movable mass as kinetic energy for acceleration. In the proposed method, as the fast opening is completed and the required gap is obtained, the closing coil is energized and used as a damping coil to generate a reverse, braking force that slows down the movement. Then, the disc spring can easily handle the remaining kinetic energy and secure the moving parts in the open position.

The approach is developed here in the context of repulsion coils. It can be extended, at least in principle, to any actuator with two (or more) coils acting in opposite directions. Some work in that area was done, for instance, on actuators with permanent magnets [17]–[19].

The research was carried out first by comprehensive transient FEM simulation, complemented by experimental evaluation. The physical equations solved by COMSOL include Maxwell's equations in the opening coil, the closing coil, and in the conductive disc, as well as the mechanical balance of force between the electromagnetic forces as derived from Maxwell's, spring forces, gravitational forces, and friction losses.

These supporting equations have been published in the previous work completed under this project [20], and similar equations were provided elsewhere [10].

The FEM modeling includes different physics (electromagnetic, mechanical, and thermal), see Fig. 7. The mechanical actuator is designed for a 630 A prototype at medium voltage range (15–50 kV). The model geometry is shown in Fig. 8. Two

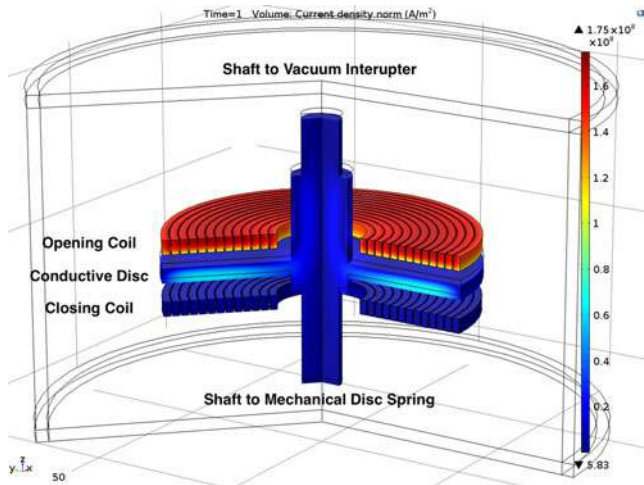

Fig. 8. 3-D view of the FEM model.

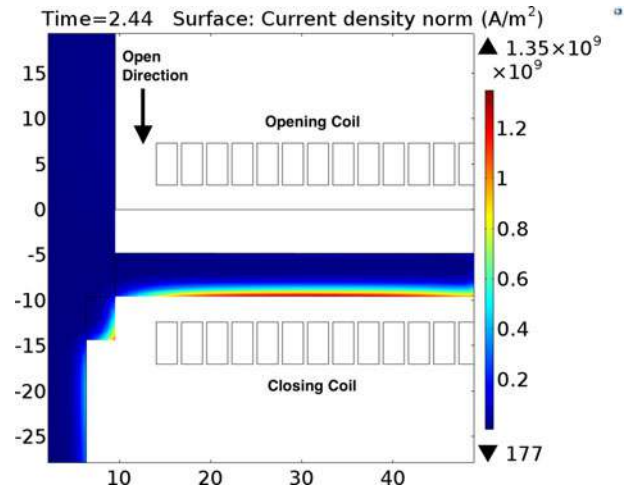
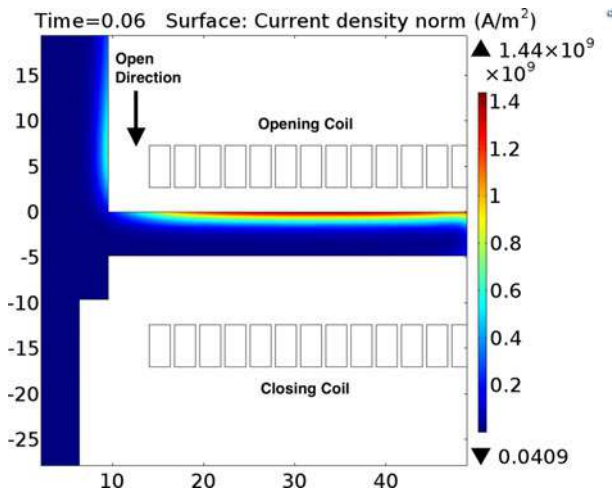
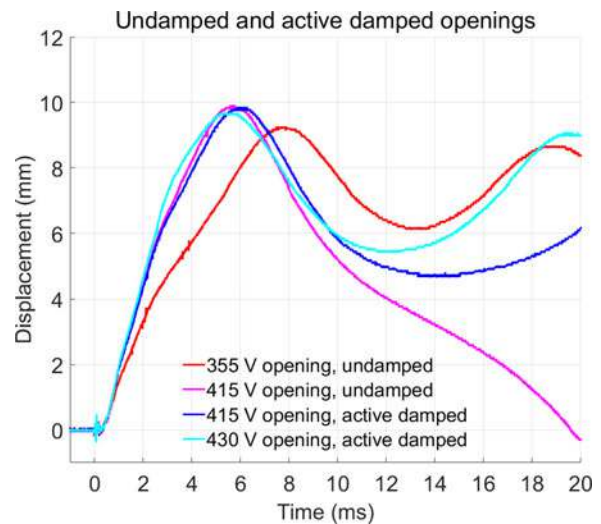

 Fig. 10. Induced current in the disc,  $440 \mu s$  after energizing the damping coil, simulation in axisymmetric 2-D view.

 Fig. 9. Induced current in the disc,  $60 \mu s$  after energizing the opening coil, simulation in axisymmetric 2-D view.

Fig. 11. Damped and undamped operations.

typical snapshots of the simulated transients are presented in Figs. 9 and 10 to illustrate the eddy currents induced in the conductive copper disc upon the energization of the opening coil and the damping coil, respectively.

Fig. 11 shows four displacement curves in different operations. The red curve shows the gap opening transient when the opening coil is driven by a moderate voltage level of 355 V. The travel reaches 3 mm at 2 ms and settles to a steady-state position of approximately 7–8 mm with 1.5 mm overshoot. When opening voltage is as high as 415 V (the purple curve), the moving contact overshoots more than 2 mm and recloses because the excessive kinetic energy is not damped out by the mechanical structure. In this case, the reclosure is avoided when using active damping (the blue curve). Therefore, the active damping method is proved to enable higher speed operation and prevent reclosing during opening operations. The light blue curve shows that with the active damping, opening voltage can be even higher, such as 430 V, so that faster opening operation can be achieved.

#### IV. DESIGN OF THE ACTIVE DAMPING CONTROL

The general principle of active damping was presented in Section III. This section addresses how to design the damping control, or in other words when and by how much the damping coil should be energized. For a given pulse of the opening coil, there are a few variables in the damping pulse that can be changed to achieve the best performance for a given design of an UFMS. They correspond to the timing, magnitude, and shape of the damping pulse, the magnitude and shape being controlled by the capacitance and voltage of the capacitor bank exciting the damping coil. If the same capacitor bank is used for both opening and closing operation, as is preferable for simplicity and to minimize cost, it is also the same for the damping operation. Therefore, timing is the most convenient parameter to affect the damping performance. Voltage and capacitance may be used as additional degrees of freedom, if their impact on performance justifies the extra complexity.

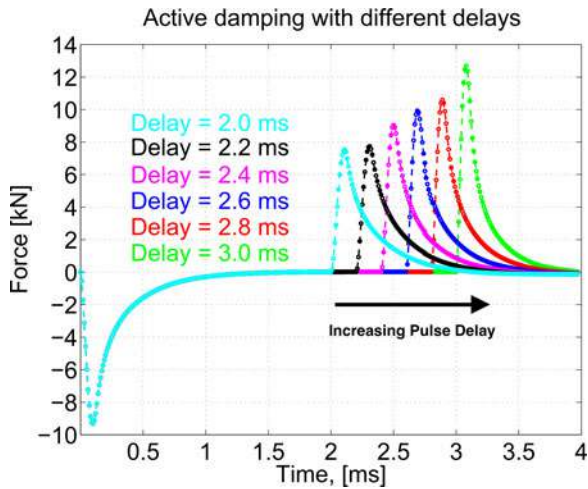

Fig. 12. Driving force (from 0 to 2 ms) and damping forces (from 2 to 4 ms), simulation results.

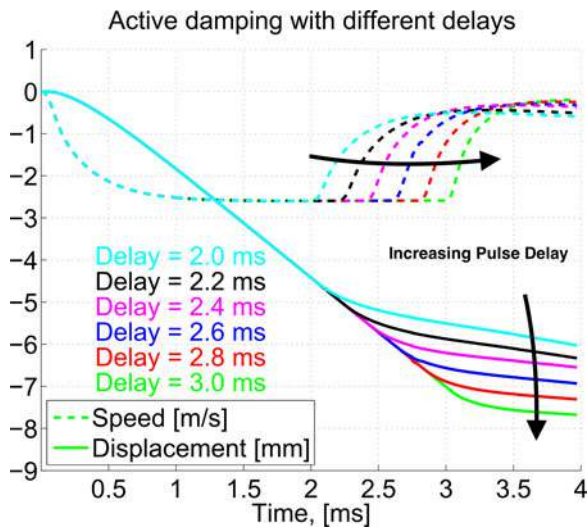

Fig. 13. Speed and displacement curves corresponding to Fig. 12 forces, simulation results.

Figs. 12 and 13 illustrate the active damping effects, as calculated by transient FEM modeling when the braking coil is energized at different times, with the same voltage and capacitance. Referring to Fig. 12, a negative force accelerates the moving mass, starting at time 0. Then, a positive force later dampens the movement, starting at time 2 ms or later (several model runs are superimposed on the same graph, all starting with the same opening pulse). Fig. 13 shows the corresponding displacements (solid traces) and velocities (dashed curves).

With a capacitor bank of 2 mF pre-charged to 400 V, the actuator is accelerated to 2.6 m/s (see Fig. 13). At 2 ms, the gap in the switch reaches 4.5 mm, which can withstand 60 kV. A sweep of delay times from 2.0 to 3.0 ms is presented in Figs. 12 and 13, and the following observations can be made.

- 1) Energizing the braking coil has an immediate effect to dampen the opening movement. Braking, therefore, should not be initiated before the specified gap and

opening time are reached, 4.5 mm and 2 ms, respectively, in this case.

- 2) The later the damping coil is energized, the closer the copper discs proximity is to the damping coil at time of actuation, therefore, the damping force increases. Conversely, with shorter delays, the disc may be too far for the damping coil to have any substantial effect, the disc being out of range, so to speak. The largest peak damping force was obtained with a 3-ms delay. It is 160% of the one with a 2-ms delay.

There is, therefore, an opportunity for optimization, with later pulses being more powerful, but intervening farther in the travel. Fig. 13 shows when the damping force starts to operate, and also shows the position at which the disc comes to a stop.

- 3) An earlier damping pulse results in a weaker force and takes a longer time to reduce the kinetic energy of the moving mass. But the travel is limited to a smaller range (the disc stops at position 6 mm at time 4 ms).
- 4) A later damping results in a stronger force, takes a shorter time to reduce the kinetic energy of the moving mass. However, the movable contact tends to travel further (7.7 mm at 4 ms).

## V. EXPERIMENTAL TESTS OF ACTIVE DAMPING

Experimental tests were performed on a Thomson coil actuated UFMS to verify the active damping approach and the FEM model. These results provide additional validation of both the calculated parameters of active damping, and the interactions that occur between the coils and the conductive disc.

### A. Test Setup

A prototype of a Thomson coil actuated UFMS and associated driving mechanism was used to test the active damping approach in a laboratory setting. More details regarding the mechanical switch can be found in [8]. The closing coil was used as the damping coil; two capacitor banks of the same capacitance were independently controlled by two thyristor switches to energize the opening coil and the damping coil. The physical setup is shown in Fig. 14.

The test setup allows incremental variations of the opening coil voltage, damping coil voltage, and trigger delay between the opening and damping current pulses. Testing has been conducted using the parameters listed in Table I. Figs. 15 and 16 show which combinations of parameters led to a successful opening, and which led to reclosure.

### B. Measurement and Control of Test Setup

A high-level measurement and control diagram shown in Fig. 17 represents the control inputs and measurement outputs from the prototype test bench. Two power supplies charge the opening and closing coil capacitor banks, which are then discharged through the Thomson coils via power thyristors. The user inputs and control, annotated in green in Fig. 17 control the timing delay and voltage applied which is a variable for



Fig. 14. Test setup of the active damping method.

 TABLE I  
 COMBINATIONS OF OPENING VOLTAGES, DAMPING VOLTAGES, AND DAMPING DELAYS TESTED

| Opening voltage | Damping voltage                                 | Damping delay |
|-----------------|---|---------------|
| 355 V           | 322 V   | 2.0 ms        |
| 370 V           | 345 V   | 2.2 ms        |
| 385 V           | 365 V   | 2.4 ms        |
| 400 V           | (for selected opening voltage and delay values) | 2.6 ms        |
| 415 V           |   | 2.8 ms        |
| 430 V           |   | 3.0 ms        |

experimentation. In red, the measurements of the system mainly include: Currents of the opening and closing coils via a Rogowski coil and the displacement from a linear potentiometer mounted to the moving shaft.

The voltage signal generated by the displacement sensor indicates the travel, and the derivative of this signal is the velocity. Together these measurements are used to track the position, speed, and signals associated with operation with respect to time. The test bench offers great flexibility in operating the UFMS switch under variable conditions to systematically test various operating conditions.

### C. Comparison of COMSOL Simulation With Test Results

Simulation accuracy is verified through comparison of the COMSOL multiphysics simulation and the actively damped UFMS test-bench experimental results. Fig. 18 shows the comparison of a 400 V opening and 345 V damping simulation with experiment. Two cases are shown corresponding to damping-pulse delays of 2.0 and 3.0 ms. The timing, velocity, and overall shape of simulated and test-bench results verify the accuracy of the model after the 1 ms point. Deviation between simulated and experimental data within the first millisecond are

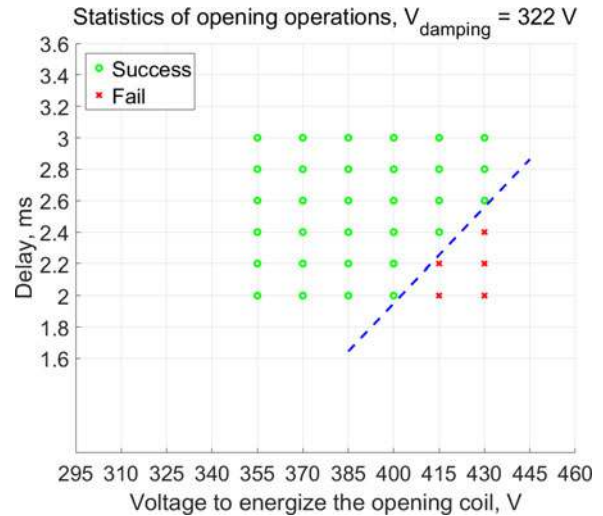

Fig. 15. Opening operations with varying opening voltages and damping delays with a damping voltage of 322 V.

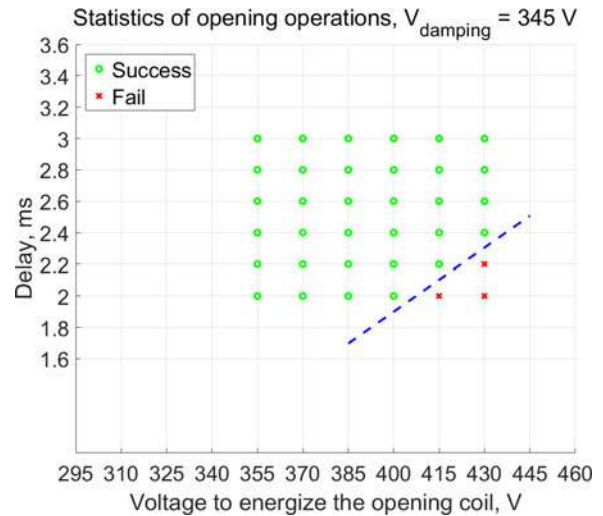

Fig. 16. Opening operations with varying opening voltages and damping delays with a damping voltage of 345 V.

likely due to the following sources of error not accounted for in modeling.

- 1) Stiction of the two physical bodies that requires additional force to overcome stationary friction prior to beginning motion. The simulation did not include stiction.
- 2) The mechanical spring in use is a disc spring that has a nonlinear force-deflection characteristic. Although the spring and its nonlinearity were modeled, its exact characteristic may have lacked precision over a portion or all of the spring force-displacement curve.
- 3) Contact slippage or lag of potentiometer position sensor due to the rapid acceleration of the moving mass.
- 4) The COMSOL simulation predicts force which is then compared to motion, amplifying any error in the double integral.

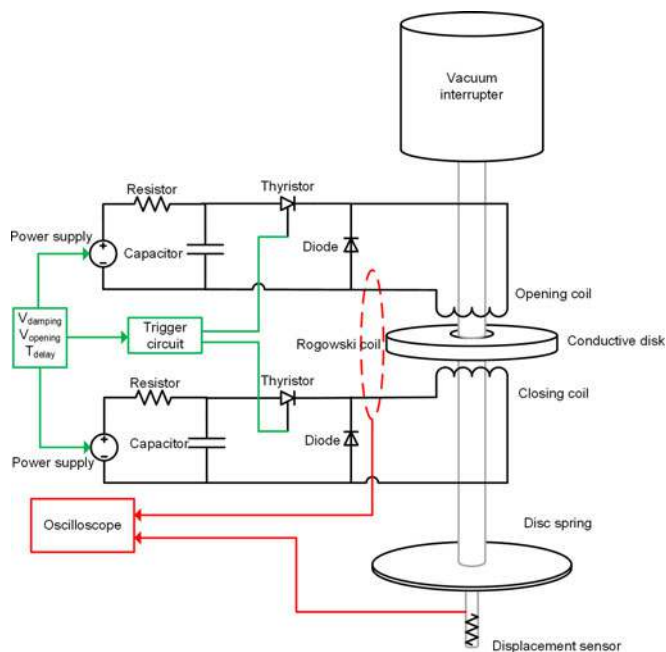

Fig. 17. Measurement and control diagram of the Thomson coil actuated, actively damped, UFMS.

400 Volt Opening, 345 Volt Damping COMSOL Simulation Compared to Experimental Results - 4ms

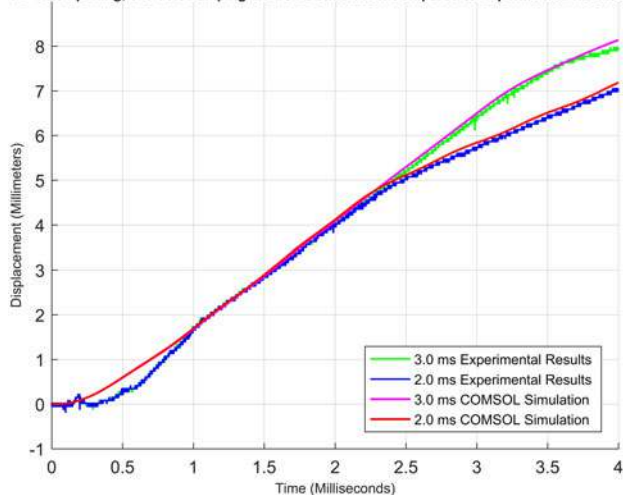

Fig. 18. Comparison of experimental test-bench results to COMSOL simulated results.

#### D. Contribution of Opening Voltage

The impact of opening voltage for a fixed damping delay (either 2 or 3 ms) is shown as displacement curves in Figs. 19–22. Also shown in the figures, for reference, is one trace corresponding to the current pulses in the opening and damping coils. The force exerted on the movable mass for opening and, therefore, the acceleration of the opening contacts are controlled through the opening voltage applied to the opening coil. Increasing this opening voltage and, therefore, the magnitude of the current, which flows through the opening coil, results in higher speeds being achieved during opening operation. However, this also results in greater kinetic energy that must be damped out of the system. The figures show traces for opening voltages ranging

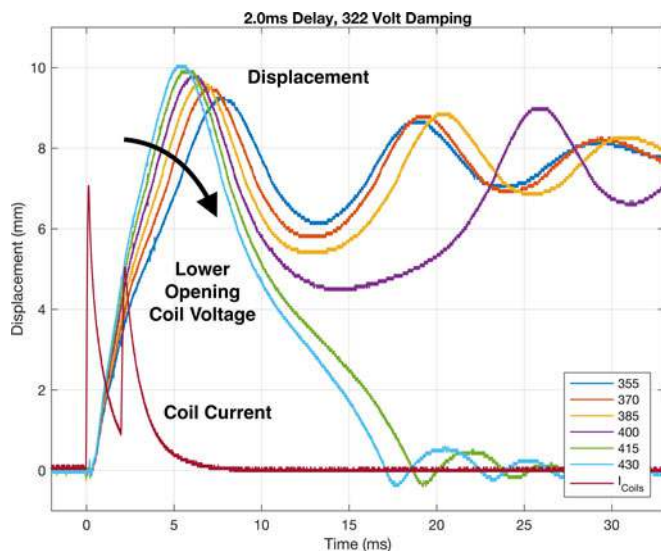

Fig. 19. UFMS motion for various opening voltages, with 2.0 ms damping delay and 322-V damping voltage.

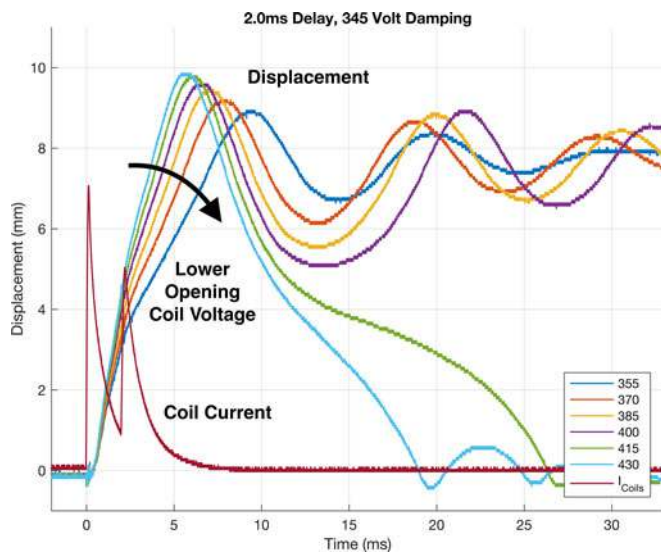

Fig. 20. UFMS motion for various opening voltages, with 2.0-ms damping delay and 345-V damping voltage.

from 355 to 430 V. Lower opening coil voltages, such as 340 V, are insufficient to open at all.

The variable voltage operations show that 3.0 ms damping is adequate to prevent reclosing of all test voltages as shown in Figs. 21 and 22. Given that the opening voltage was varied from 355 to 430 V, this indicates a very favorable robustness for the system. That is, the system is able to guarantee a successful opening over a wide range of parameters, an important consideration for a device that is expected to perform reliably over a long period of time in varying environmental and other conditions.

With a shorter delay (the damping pulse starting at 2 ms, Figs. 19 and 20, opening fails (large bounces leading to reclosure) if the damping pulse is too strong, see for instance traces 415 and 430 V in Fig. 19. This is primarily due to the distance from the damping coil at time of current flow. At 2.0 ms, the

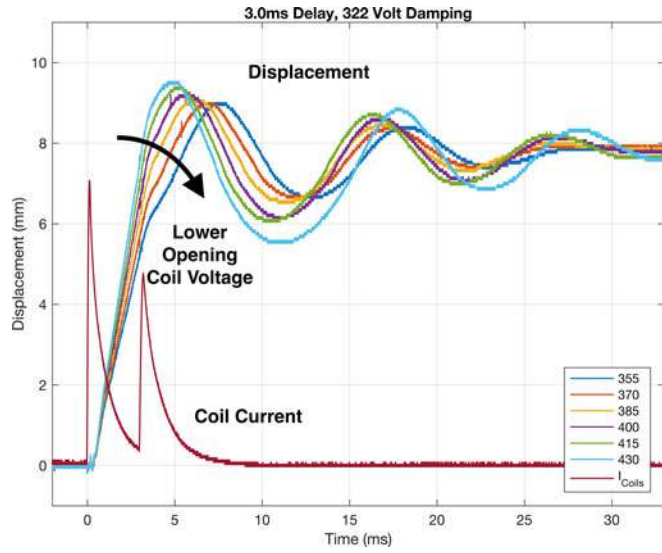

Fig. 21. UFMS motion for various opening voltages, with 3.0-ms damping delay and 322-V damping voltage.

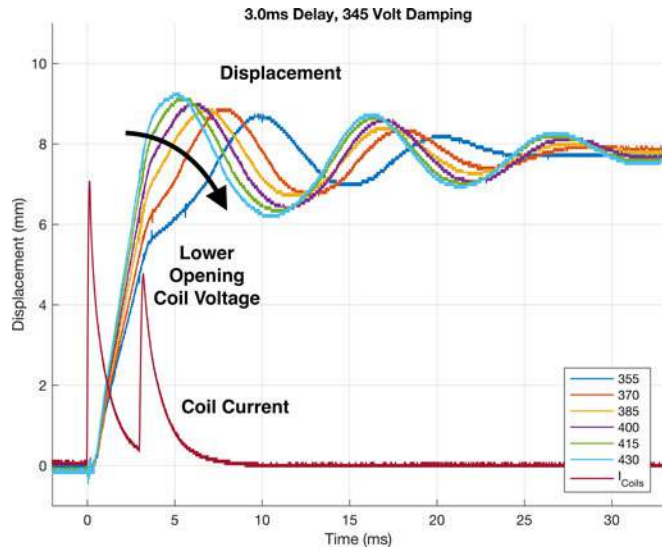

Fig. 22. UFMS motion for various opening voltages, with 3.0-ms damping delay and 345-V damping voltage.

conductive disc is not within an effective range of the damping coil and cannot transfer enough kinetic energy to the damping coil. The excess kinetic energy remaining in the moving mass is too large for the disc spring to absorb, resulting in underdamping and eventual rebound, or reclosing of the switch.

*E. Contribution of Damping Voltage*

The effect of the damping voltage is shown in Fig. 23. Within the range of 322 to 365-V damping voltages, the system opened the contact successfully. Further, it can be observed that the damping voltage has a significant impact on the amount of overshoot.

In terms of design, the damping coil is the same used for closing the actuator after the fault has been cleared. It appears that it may be desirable to have two different voltage levels in

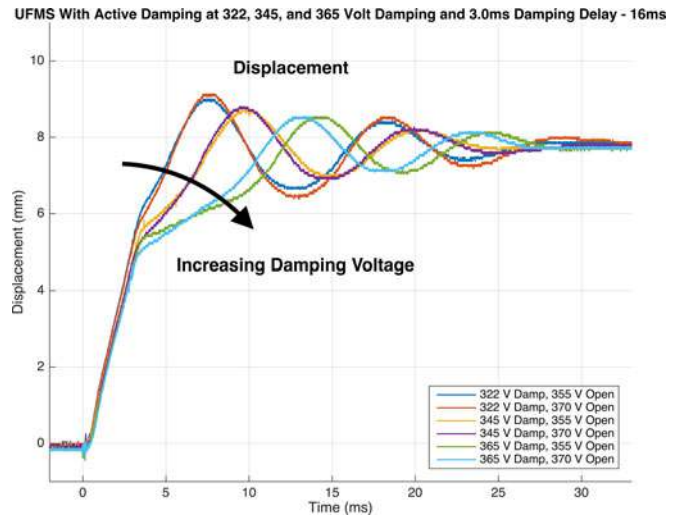

Fig. 23. UFMS motion for various opening and damping voltages, with 3.0-ms delay.

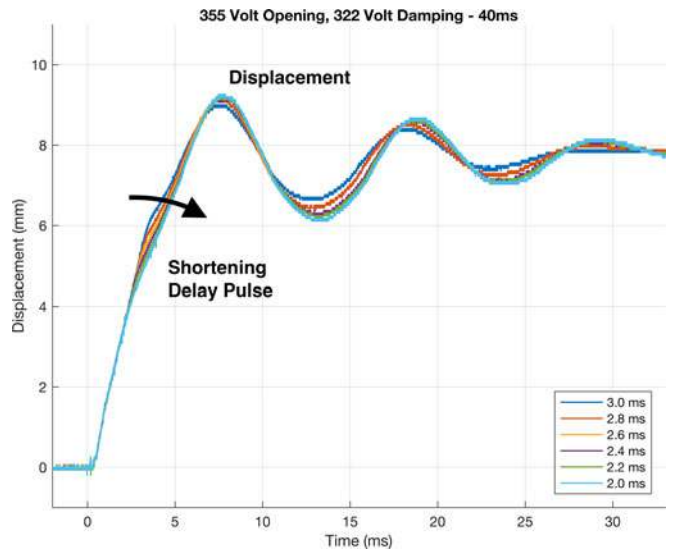

Fig. 24. UFMS motion for various damping pulse timings with 430-V opening voltage and 322-V damping voltage.

the design: For normal closing operation, the voltage should be smaller, simply large enough to close the switch reliably and avoid slamming and damage. However, higher closing coil voltages may be preferable for damping operations.

Having two operating voltages for this coil, one for normal closing and one for damping the opening pulse can be implemented with no additional complexity to the physical switch or driving mechanisms.

*F. Contribution of Damping Pulse Timing*

How the time delay affects the damping transients is shown in Figs. 24 and 25.

In both cases of 322 and 345-V damping voltages, a shorter pulse delay (comparing 2 with 3 ms) would generate a slightly higher overshoot in the traveled distance and relatively larger oscillation magnitudes later on. This is because at 2 ms the moving disc had not yet arrived in the most effective region



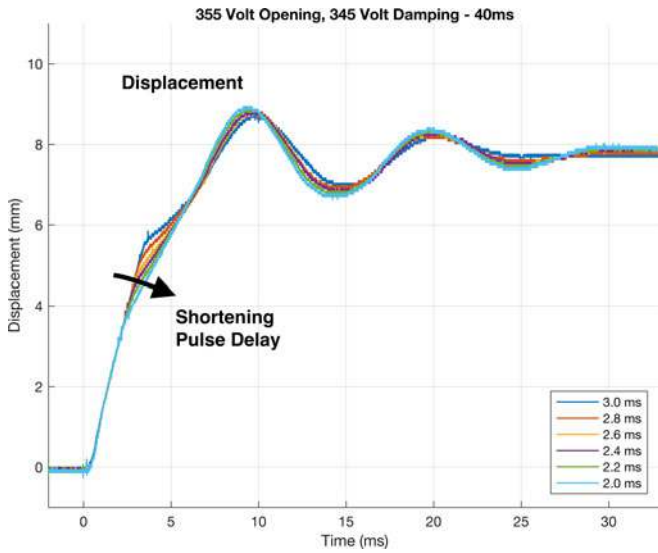

Fig. 25. UFMS motion for various damping pulse timings with 430-V opening voltage and 345-V damping voltage.

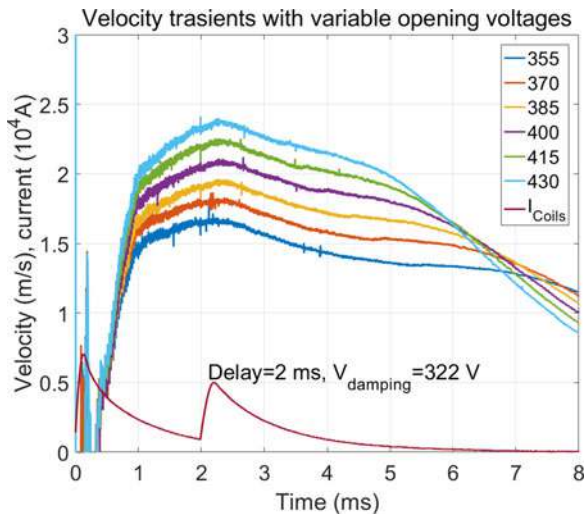

Fig. 26. UFMS velocity pattern for various opening voltages, with 2.0-ms damping delay and 322-V damping voltage.

for the damping coil to absorb the kinetic energy. However, the length of the damping period for an early damping pulse is longer than the one for a late one.

Figs. 26 and 27 show velocity plots. Two observations can be made: With increased opening voltages, faster peak speeds are obtained, resulting in faster operation. Yet at the same time, with increased opening voltage, the effectiveness of the damping pulse with the same damping voltage and delay is increased. This is because a higher opening voltage drives the moving mass closer to the damping coil within the same period of time.

## VI. DISCUSSIONS

In summary, the following lessons have been learned during the simulation and test bench prototype study completed in this research.

- 1) Thomson coil actuators provide ultrafast operation, and if two coils are present, the second coil can provide effective

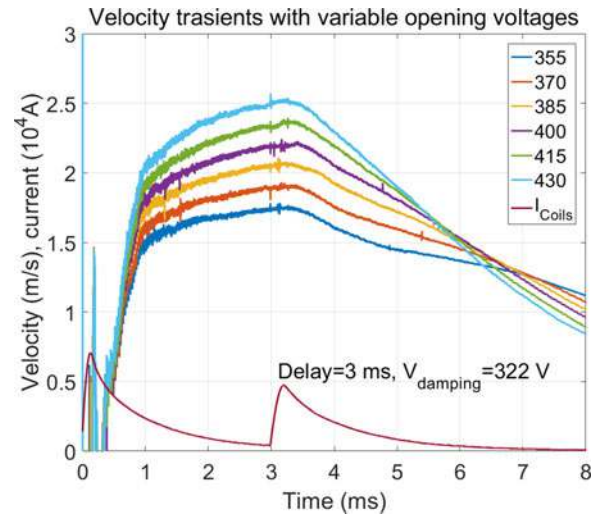

Fig. 27. UFMS velocity pattern for various opening voltages, with 3.0-ms damping delay and 322-V damping voltage.

active damping without increasing physical system complexity.

- 2) With active damping, faster opening can be obtained by increasing the opening energy voltage with no risk of bounce or contact reclosing.
- 3) Eddy currents are generated in the conductive disk due to the time varying magnetic field, therefore, rise and fall time of the current in each coil is of key importance. A high-energy discharge due to large voltage in the capacitor bank through a small number of turns ensures a high  $\frac{di}{dt}$  and, therefore, a strong repulsive force between the coil and the conductive disc.

Successful and effective active damping is predicated primarily on the relative position of the conductive disk when the second coil is actuated. The appropriate distance to activate the second coil is a function of the current rise time and the speed of the conductive disk. In the simulation and experimental results presented in this paper with a large capacitor bank and a very low number of turns in the coil, current rise happens relatively immediately compared to the mechanical motion of the disc as shown in Figs. 19–22. Therefore, actuation of the damping coil is optimal near the very end of travel.

Potential future deployments of this technology will benefit from a better understanding of the limits of this approach in terms of how much faster such a Thomson coil actuator could operate and then ensuring the repeatability over time of such performance enhancement. The mechanical endurance of the other components such as the vacuum interrupter need to be examined. This reliability testing is critical for the practical use of the method beyond the laboratory.

In the end, this paper concludes that damping at the end of motion can actually be used to design yet faster actuators. While we demonstrated this in the context of Thomson coil actuators, there are reasons to believe that this could apply to other actuators as well, particularly when two coils are present.

## VII. CONCLUSION

A novel active damping mechanism has been proposed to address the reclosing issues observed during high-speed operation of Thomson coil actuated fast mechanical switches. The concept has been verified by a comprehensive transient FEM model based on coupled multiphysics involved in the operation, and with validation from experiments carried out on a dc breaker prototype. Fig. 11 shows a clear demonstration of how the active damping method can stabilize the fast opening operation and the potential of achieving much higher opening speeds.

An important contribution of this paper is that active damping helps absorb kinetic energy and minimizes the side effects of high actuator speed. It also makes it possible to select operating parameters that lead to faster, yet reliable, operation.

Evaluation of different damping delays for a particular design has been presented. It is found that earlier damping pulses result in weaker damping forces, whereas later damping pulses generate stronger forces because the disc and coils are closer to one another at the onset of the braking pulse. The optimization of the damping pulse should be a function of the design specifics, including the layout of the coils and the moving disc, as well as the disc spring characteristics.

## REFERENCES

- [1] J. Häfner and B. Jacobson, "Device and method to break the current of a power transmission or distribution line and current limiting arrangement," WO Patent 057 675 A1, May 19, 2011.
- [2] J. Häfner and B. Jacobson, "Proactive hybrid HVdc breakers—A key innovation for reliable HVdc grids," in *Proc. Cigré Symp.*, vol. 264, 2011, pp. 1–8.
- [3] A. Burnett, C. Oates, and C. Davidson, "High voltage dc circuit breaker apparatus," WO Patent App. PCT/EP2012/053,574, Sep. 6, 2012.
- [4] C. Peng, A. Q. Huang, M. A. Rezaei, X. Huang, and M. Steurer, "Development of medium voltage solid-state fault isolation device for ultra-fast protection of distribution system," in *Proc. 40th IEEE Annu. Conf. IEEE Ind. Electron. Soc.*, 2014, pp. 5169–5176.
- [5] A. Huang, C. Peng, and X. Song, "Design and development of a 7.2 kV/200 A hybrid circuit breaker based on 15 kV SiC emitter turn-off (ETO) thyristor," in *Proc. 2015 IEEE Elect. Ship Technologies Symp.*, Jun. 2015, pp. 306–311.
- [6] C. Davidson, R. Whitehouse, C. Barker, J.-P. Dupraz, and W. Grieshaber, "A new ultra-fast HVdc circuit breaker for meshed dc networks," in *Proc. 11th IET Int. Conf. AC DC Power Transmiss.* IET, 2015, pp. 1–7.
- [7] A. Bissal, J. Magnusson, E. Salinas, G. Engdahl, and A. Eriksson, "On the design of ultra-fast electromechanical actuators: A comprehensive multi-physical simulation model," in *Proc. 2012 6th Int. Conf. Electromagn. Field Probl. Appl.*, Jun. 2012, pp. 1–4.
- [8] C. Peng, I. Husain, A. Huang, B. Lequesne, and R. Briggs, "A fast mechanical switch for medium voltage hybrid DC and AC circuit breakers," *IEEE Trans. Ind. Appl.*, vol. 52, no. 4, pp. 2911–2918, Jul./Aug. 2016.
- [9] C. Peng, A. Huang, I. Husain, B. Lequesne, and R. Briggs, "Drive circuits for ultra-fast and reliable actuation of Thomson coil actuators used in hybrid ac and dc circuit breakers," in *Proc. 2016 31st Annu. IEEE Appl. Power Electron. Conf. Expo.*, 2016, pp. 2927–2934.
- [10] S. Fang, M. Xia, H. Lin, and S. Ho, "Analysis and design of a high-speed permanent magnet characteristic actuator using eddy current effect for high-voltage vacuum circuit breaker," *IET Elect. Power Appl.*, vol. 10, no. 4, pp. 268–275, 2016.
- [11] W. Wen *et al.*, "Research on operating mechanism for ultra-fast 40.5 kV vacuum switches," *IEEE Trans. Power Del.*, vol. 30, no. 6, pp. 2553–2560, Dec. 2015.
- [12] C. Peng, L. Mackey, A. Huang, I. Husain, B. Lequesne, and R. Briggs, "Active damping of ultra-fast mechanical switches for hybrid ac and dc circuit breakers," in *Proc. IEEE Energy Convers. Conf. Expo. (ECCE)*, Milwaukee, WI, 2016, pp. 1–8.

- [13] B. Roodenburg, M. A. Kaanders, and T. Huijser, "First results from an electro-magnetic (EM) drive high acceleration of a circuit breaker contact for a hybrid switch," in *Proc. 2005 Eur. Conf. Power Electron. Appl.* 2005, pp. 1–10.
- [14] B. Roodenburg and B. H. Evenblij, "Design of a fast linear drive for (hybrid) circuit breakers—Development and validation of a multi domain simulation environment," *Mechatronics*, vol. 18, no. 3, pp. 159–171, 2008.
- [15] J.-M. Meyer and A. Rufer, "A DC hybrid circuit breaker with ultra-fast contact opening and integrated gate-commutated thyristors (IGCTs)," *IEEE Trans. Power Del.*, vol. 21, no. 2, pp. 646–651, Apr. 2006.
- [16] P. Skarby, D. Ohlsson, J. Korbil, L. E. Jonsson, and L. Liljestränd, "Fast switch with Thomson coil and damping," EP Patent 2 546 847 B1, Jan. 16, 2013.
- [17] K. Peterson, A. Stefanopoulou, T. Megli, and M. Haghgoie, "Output observer based feedback for soft landing of electromechanical camless valvetrain actuator," in *Proc. 2002 Amer. Control Conf. (IEEE Cat. No. CH37301)*, vol. 2, 2002, pp. 1413–1418.
- [18] R. R. Chladny and C. R. Koch, "Flatness-based tracking of an electromechanical variable valve timing actuator with disturbance observer feedforward compensation," *IEEE Trans. Control Syst. Technol.*, vol. 16, no. 4, pp. 652–663, Jul. 2008.
- [19] N. Gelez, E. Talon, and B. Bouchez, "Method of controlling an actuator having a movable member with positional feedback control," US Patent 8 443 771, May 21, 2013.
- [20] C. Peng, I. Husain, and A. Huang, "Evaluation of design variables in Thomson coil based operating mechanisms for ultra-fast opening in hybrid AC and DC circuit breakers," in *Proc. 30th IEEE Annu. Appl. Power Electron. Conf. Expo.*, 2015, pp. 2325–2332.



**Chang Peng** (S'13–M'16) received the B.Sc. degree from the Huazhong University of Science and Technology, Wuhan, China, in 2009; the M.Sc. degree from the China Electric Power Research Institute, Beijing, China, in 2012; and the Ph.D. degree from North Carolina State University, Raleigh, NC, USA, in 2016, all in electrical engineering.

He is currently a Power Electronics Engineer with Hyperloop One, Los Angeles, CA, USA. He has published more than 30 peer-viewed journal articles and conference papers. His research interests

include electromagnetic and solid-state power conversion systems, especially high-performance electromagnetic devices and their drives, high-power SiC and Si devices, and circuit interruption and protection in dc and ac power systems.

Dr. Peng has received the IEEE Industry Applications Society Prize Paper in 2016, the Best Paper Award from the IEEE Energy Conversion Congress and Exposition (ECCE) in 2016, the Best Presentation Award from the IEEE Applied Power Electronics Conference and Exposition (APEC) in 2015, and the Best Presentation Recognition from the IEEE Industrial Electronics Conference (IECON) 2014.



**Landon Mackey** (M'14) received the B.S. degree in electrical engineering and the M.S. degree in electric power systems engineering from North Carolina State University, Raleigh, NC, USA, in 2015 and 2016, respectively, where he is currently working toward the Ph.D. degree in electrical engineering.

He operated nuclear submarines as a Nuclear Electrician in the U.S. Navy; designed and tested modular multilevel power converters at ABB Corporate Research Center, Dättwil, Aargau, Switzerland; and launched a dc fast charge system at Ford Motor Company, Dearborn, MI, USA. He is currently a Research Assistant with the Future Renewable Electric Energy Deliver and Management Systems Center, Raleigh. His research interests include low voltage and medium voltage dc circuit protection, and dc microgrid design.



**Iqbal Husain** (S'89–M'89–SM'99–F'09) received the Ph.D. degree in electrical engineering from Texas A&M University, College Station, TX, USA, in 1993.

He is currently the Director with the FREEDM National Science Foundation Engineering Center, Raleigh, NC, USA, and the ABB Distinguished Professor with the Department of Electrical and Computer Engineering, North Carolina State University (NC State), Raleigh. He also serves as the Director with the Advanced Transportation Energy Center with NC State. Prior to joining NC State, he was at the University of Akron, Akron, OH, USA, where he built a successful power electronics and motor drives program. He was a visiting Professor at Oregon State University, Corvallis, OR, USA, in 2001. His expertise is in the areas of power electronics, electric machines, motor drives, and system controls. He made unique contributions for the design and control of electric machines and drives through his modeling- and analysis-based research activities. In the FREEDM Center, his research is focused on power electronics integration into power systems. He has also developed innovative graduate and undergraduate courses on electric and hybrid vehicles, and published a textbook on the subject.

Dr. Husain received the 2006 Society of Automotive Engineers (SAE) Vincent Bendix Automotive Electronics Engineering Award, the 2004 College of Engineering Outstanding Researcher Award, the 2000 IEEE Third Millennium Medal, and the 1998 IEEE-Industry Applications Society Outstanding Young Member Award. He was the Distinguished Lecturer of the IEEE Industry Applications Society for 2012–2013. He is the Editor-in-Chief of IEEE ELECTRIFICATION MAGAZINE.



**Alex Q. Huang** (S'91–M'94–SM'96–F'05) was born in Zunyi, China. He received the B.Sc. degree from Zhejiang University, Hangzhou, China, in 1983, and the M.Sc. degree from the Chengdu Institute of Radio Engineering, Chengdu, China, in 1986, both in electrical engineering, and the Ph.D. degree in electrical engineering from Cambridge University, Cambridge, U.K., in 1992.

From 1992 to 1994, he was a Research Fellow at Magdalene College, Cambridge. From 1994 to 2004, he was a Professor in the Bradley Department of Electrical and Computer Engineering, Virginia Polytechnic Institute and State University, Blacksburg, VA, USA. From 2004 to 2017, he was the Progress Energy Distinguished Professor of electrical and computer engineering at North Carolina State University, Raleigh, NC, USA, where he established and led the National Science Foundation (NSF) FREEDM Systems Center. Since 2017, he has been the Dula D. Cockrell Centennial Chair in engineering with the University of Texas at Austin, Austin, TX, USA. Since 1983, he has been involved in the development of modern power semiconductor devices and power integrated circuits. He fabricated the first insulated gate bipolar transistor power device in China in 1985. He is the inventor and key developer of the emitter turn-off (ETO) thyristor. He developed the concept of energy Internet and the smart transformer based energy router technology. He has mentored and graduated more than 80 Ph.D. and master students, and has published more than 500 papers in international conferences and journals. He has also been granted more than 20 U.S. patents. His current research interests include power electronics, power management microsystems, and power semiconductor devices.

Dr. Huang received the NSF CAREER Award, the prestigious R&D 100 Award, and the Massachusetts Institute of Technology Reviews 2011 Technology of the Year Award.



**Wensong Yu** (M'07) received the M.S. degree from the Central China University of Science and Technology, Wuhan, China, and the Ph.D. degree from the South China University of Technology, Guangzhou, China, in 1995 and 2000, respectively, both in mechanical and electrical engineering.

From 2006 to 2013, he was a Postdoctoral Researcher, a Research Scientist, and a Research Assistant Professor at the Bradley Department of Electrical and Computer Engineering, Virginia Polytechnic Institute and State University, Blacksburg, VA, USA.

Since 2013, he has been with the Department of Electrical and Computer Engineering, North Carolina State University, Raleigh, NC, USA, as a Research Associate Professor. His current research interests include high-frequency solid-state transformer, advanced soft-switching technique, wide bandgap device applications, ultrahigh efficiency inverter, high-voltage power conversion and protection, SiC electric vehicle traction drive, distributed energy storage devices, and green energy grid infrastructure.



**Bruno Lequesne** (M'85–SM'89–F'97) received the Certified-Engineer degree in electrical engineering from Centrale-Supélec, Gif-sur-Yvette, France, in 1978, and the Ph.D. degree in electrical engineering from the Missouri University of Science and Technology, Rolla, MO, USA, in 1984.

He worked for 30 years in the automotive industry on transportation electrification research and industrial drives before starting his own consultancy, E-Motors Consulting, LLC, Menomonee Falls, WI, USA, in 2014. His automotive involvement includes

working at General Motors Research Laboratories, Warren, MI, USA (1984–1999), and Delphi Research Laboratories, Shelby Township, MI (1999–2006). In September 2006, he moved to the Delphi Powertrain Division, Auburn Hills, MI, to manage a group within the advanced powertrain engineering organization (2006–2009). After a year at the University of Alabama, Tuscaloosa, AL, USA, he joined the Eaton Corporate Research and Technology Group, Milwaukee, WI, to focus on the electrification of commercial vehicles and advanced industrial drives (2010–2014). Since starting his consultancy, he has contributed to the automotive, aerospace, and renewable energy industries working on motors, actuators, and systems. He holds 50 patents with three more pending, primarily on sensors, linear actuators, and automotive applications.

Dr. Lequesne received ten Best Paper Awards, seven from the IEEE Industry Applications Society (IAS) and three from the Society of Automotive Engineers, including the Colwell (2000) and Bendix (2007) Awards. He received the Nikola Tesla Award in 2016. He is also the past President (2011–2012) of the IEEE IAS and is currently on the steering committee of the IEEE Transportation Electrification Community.



**Roger Briggs** received the B.S. degree in engineering science from Iowa State University, Ames, IA, USA, in 1975, and the M.Ed. degree in education and the master's degree in mechanical engineering from Marquette University, Milwaukee, WI, USA, in 1982 and 1996, respectively.

He is a Mechanical Engineer with 40 years of industrial experience. Most of his career was spent performing research in the fields of electric power control, power distribution, energy efficiency, and thermal management systems at Eaton Corporation. He

is a co-inventor on nine patents. He currently runs Energy Efficiency Research, LLC, Colgate, WI, which performs engineering consulting services.